

# sisis<sup>®</sup>

## **BRUSH-PRO**

### **RIDE-ON BRUSH SYSTEM**

### **INSTRUCTION MANUAL**

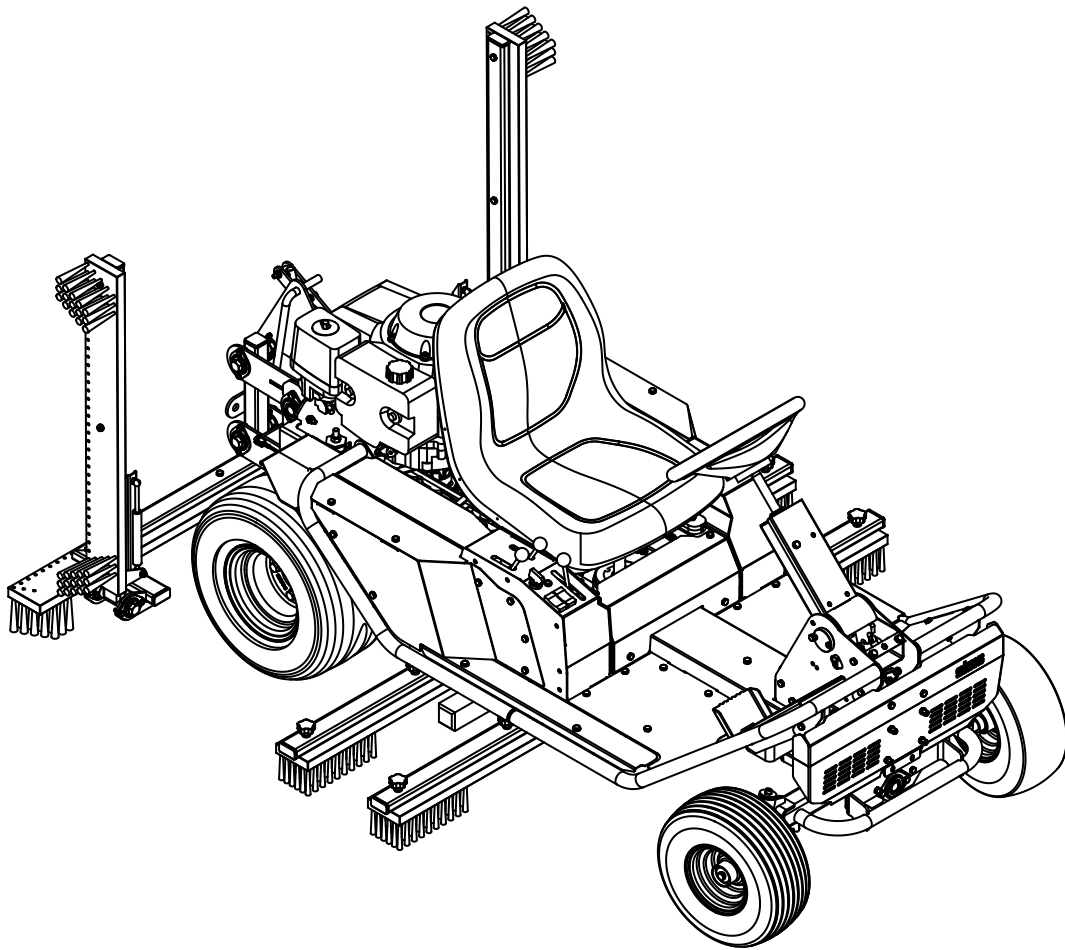

SISIS, Ashbourne Road, Kirk Langley, Derbyshire, DE6 4NJ, England.  
Tel: +44 (0) 1332 824 777 | Fax: +44 (0) 1332 824 525 | Email: [info@sisis.com](mailto:info@sisis.com) | [www.sisis.com](http://www.sisis.com)

A division of Howardson Ltd. - a proudly British company  
Company reg no 641526 - Vat No GB 345 9918 12

SP20017\_REV\_1  
02/15

# Certificate of Conformity

**Brush-Pro ride-on brush system powered by Honda GX Petrol Engine**

**Manufacturer:-** Howardson Ltd, Howardson Works, Kirk Langley, Derby, DE6 4NJ. UK

**Owner of Technical Document:-** Mr I.D. Howard, Howardson Ltd, Howardson Works Kirk Langley, Derby, DE6 4NJ, UK

**Notified Body:-** AV Technology Ltd, AVTECH house, Arkle Avenue, Stanley Green Trading Estate, Handforth, Cheshire, SK9 3RW, UK

I the under signed Declare that these machines:-

**Tested at:-** Howardson Works test site September 2011

Complies with the applicable requirements of:-

- Machine Directive 2006/42/EC
- Noise Directive 2000/14/EC (Annex VI Procedure 1)

**Managing Director**



**Ian Howard**

## Serial Numbers



**NOTE**

*MAKE A NOTE OF THE SERIAL NUMBERS OF YOUR MACHINE & ENGINE AND ALWAYS QUOTE THEM IN ANY COMMUNICATION WITH PERSONNEL AT DENNIS.*

**MACHINE SERIAL NUMBER**

**ENGINE SERIAL NUMBER**

## Introduction

The reliability and quality of performance of the **BRUSH-PRO** depends upon some simple care maintenance carried out regularly. This manual has been prepared to allow the user to carry out all such work.

It is advisable to read the instructions carefully. Proper care and attention will enable the machine to give a continuous, satisfactory, and reliable service. Failure to carry out regular lubrication and maintenance as outlined in this manual may render any guarantee or warranty invalid.

In the case of any difficulty, or if further information or advice is required, our Service Department is always at your call. In the interests of speed and accuracy of information please quote the serial numbers of the machine and engine when making enquiries.

For the **BRUSH-PRO**, this is to be found on a plate attached to the side frame. The engine number is stamped on either the crank case or the gear casing facing towards the front of the machine. We suggest you write the numbers on the front page of this book.

	<b>Page</b>
Certificate of Conformity.....	2
Serial Numbers.....	2
Introduction.....	2
Technical Data.....	3
Machine Description.....	4
Important Safety Instructions.....	5
Operating Instructions .....	6 - 7
Parts Listings.....	8 - 13

## Technical Data

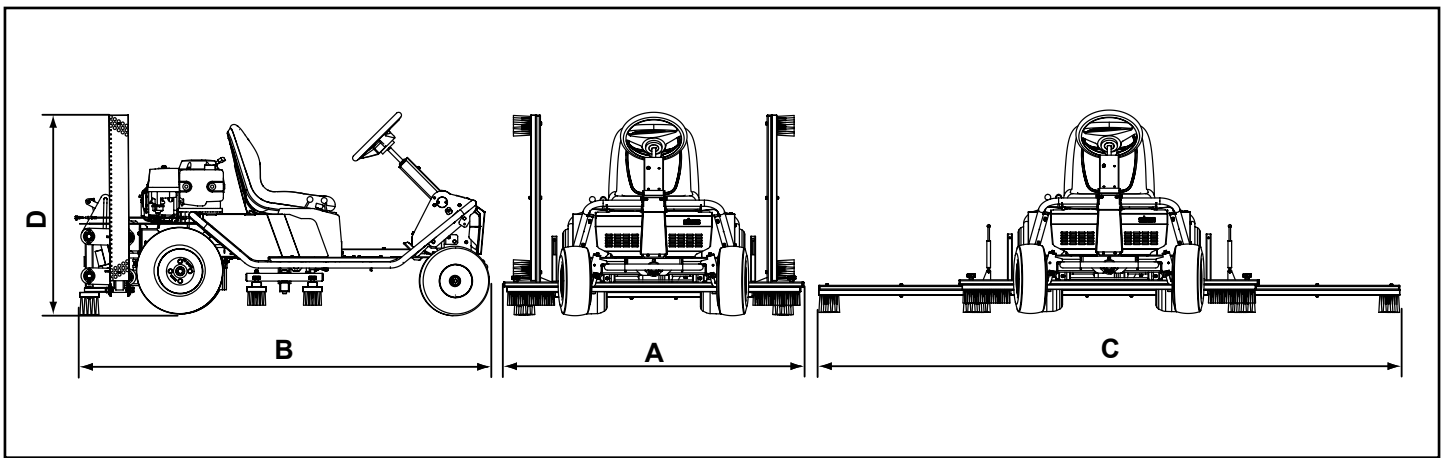

Model	Brush-Pro
A - Width (M)	1.5
B - Length (M)	2.1
C - Height (M)	1.1
D - Width - Brushes Down (mm)	3.0
Weight (Kg)	350
Engine	Honda GXV390 - 7.6kW
Drive System	Hydrostatic Transaxle
Measured Sound Power Level dB(A) LWA	91
Guaranteed Sound Power Level dB(A) LWA	94

## Machine Description

The **SISIS Brush-Pro** has been designed for use on artificial surfaces to re-distribute the infill and keep the infill material from compacting and migrating, whilst also brushing/grooming the carpet pile. The Brush Pro is powered by a 7.6 kW (10.2 Hp) air cooled 4-stroke single cylinder engine.

The Brush-Pro has 2 mid mounted oscillating brushes and a rear drag brush, both sets are lifted and lowered by electrically operated rams and which also allow for any increase in ground clearance. The centre brushes oscillate to loosen the infill and the rear drag brushes follow to settle and finish the infill. The rear brushes have two wing/outer brushes which are attached to gas springs to ensure constant and even pressure over the contact surface. The rear brushes are used daily to maintain the surface to redistribute the infill material and groom the synthetic surface.

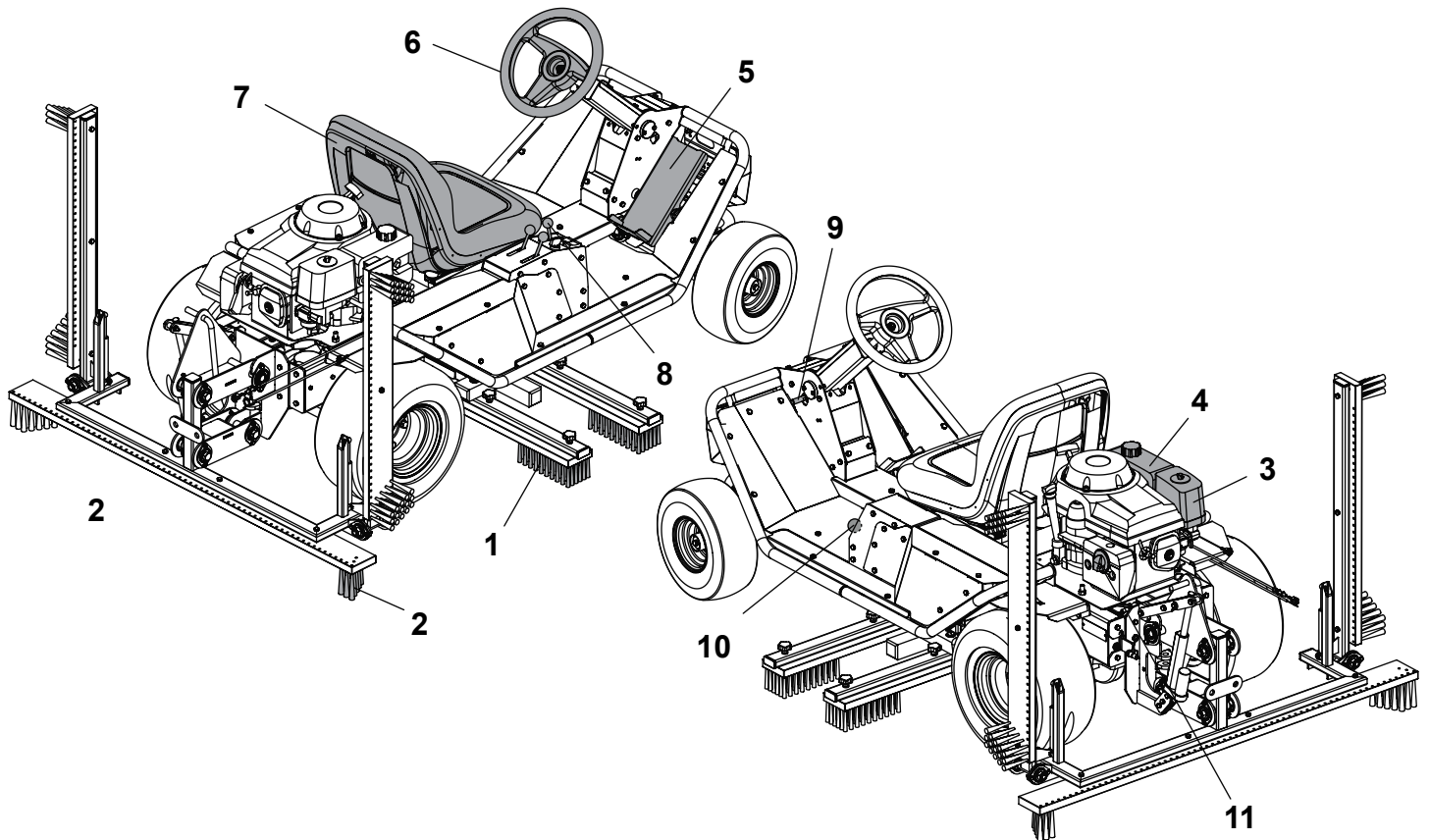

- |                   |                            |
|-------------------|----------------------------|
| 1. Centre Brushes | 7. Operator Seat           |
| 2. Rear Brushes   | 8. Operator Controls       |
| 3. Air Filter     | 9. Steering Column Release |
| 4. Fuel Tank      | 10. Axle Drive Engage Rod  |
| 5. Foot Pedal     | 11. Exhaust                |
| 6. Steering Wheel |                            |

# Important Safety Instructions

In order to operate the machine safely please follow these Health and Safety guidelines.

## TRAINING



### **CAUTION**

*READ THE INSTRUCTIONS CONTAINED IN THIS MANUAL WITH CARE. IF YOU ARE IN ANY DOUBT PLEASE ASK YOUR EMPLOYER OR CONTACT US DIRECT AT **SISIS**.*

- Be familiar with the controls and the proper use of the equipment.
- Never allow children or people unfamiliar with these instructions to use the **Brush-Pro**. Local regulations or insurance may restrict the age of the operator.
- Keep in mind that the operator or user is responsible for accidents or hazards occurring to other people or their property.

## PREPARATION



### **WARNING**

*PETROL IS HIGHLY FLAMMABLE AND WILL DAMAGE GRASS IF SPILT.*

- A) Store fuel in containers specifically designed for this purpose.
  - B) Refuel out doors and do not refuel whilst smoking.
  - C) Add fuel before starting the engine. Never remove the cap of the fuel tank or add petrol while the engine is running or when the engine is hot.
  - D) If petrol is spilled do not attempt to start the engine but move the machine away from the area of spill and avoid creating any sources of ignition until the vapours have dissipated.
- Replace damaged or faulty silencers.
  - Before using the machine always inspect the safety devices including the cut off switch and the blades for excessive wear or damage. Replace if necessary.

## OPERATION

- Do not operate the engine in a confined space where dangerous **CARBON MONOXIDE** fumes can collect.
- Use extreme caution when reversing or pulling the machine towards you.



## CAUTION

**BEFORE YOU OPERATE THIS MACHINE YOU MUST READ AND STUDY THIS MANUAL. IF YOU ARE IN ANY DOUBT PLEASE ASK YOUR EMPLOYER OR CONTACT US DIRECT.**

### OPERATING INSTRUCTIONS

Before operating the **Brush-Pro** ensure the drive engage lever is pushed in fully to disengage the rear drive axle (**See Figure 1**). This allows safe starting of the motor whether the user is seated or standing at the side of the machine. The engine will not start if the operator is unseated with the drive engage lever in the engaged position, fully out. Check that the brake is on (**See Figure 2**) and that the centre and rear brushes (**Item 1 & 2, Machine Description**) are off the ground, see 'Operating the Brushes' and disengaged with the brush engage lever in the off position.

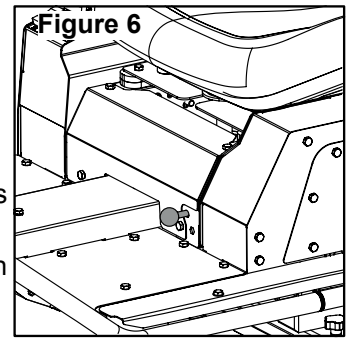

The Honda GXV390 is equipped with electric key start or recoil start at the engine. Before starting the **Brush-Pro** ensure the drive engage lever (**Item 10, Machine Description**) is pushed in fully to disengage the rear drive axle. Once seated the drive engage lever can be pulled out fully to engage drive, this fully activates the foot pedal.

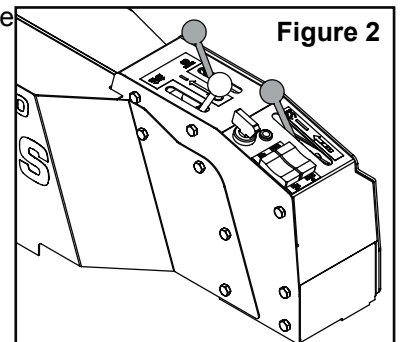

To start the engine from cold pull the throttle lever back to the choke position (**See Figure 2**), and turn the ignition key. Release the key once the engine has started and allow the engine to warm up. To stop the engine turn the ignition switch to the off position. Use the recoil start if the battery is not charged sufficiently to start the engine.

Once the engine is warm release the brake lever to the off position (**See Figure 3**) and depress the Operator's Pedal (**Item 5, Machine Description**).

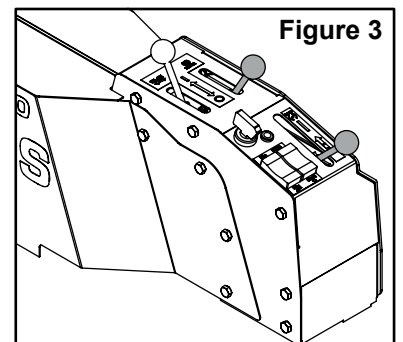

The **Brush-Pro** is driven by a Hydrostatic Axle, with the axle engaged (lever fully out) pressing the top of the pedal gives forward motion and pressing the bottom of the pedal puts the **Brush-Pro** into reverse. Releasing the pedal stops the **Brush-Pro**. The drive is proportional to the travel of the pedal.

The engine will cutout if the pedal is pressed significantly without releasing the brake lever, thus protecting the rear axle brake.

### OPERATING THE BRUSHES

The **Brush-Pro** is fitted with oscillating centre brushes and a set of rear finishing brushes. The rear brushes have two outer wing brushes which can be lowered into place giving a wide finishing width and even ground pressure (**See Figure 4**). Both the centre and rear brushes are height controlled via electric rams, with two rocker switches on the control panel, (**See Figure 5**). The centre brushes can also be used as drag brushes or by engaging drive in oscillating motion to aggravate and redistribute the infill material.

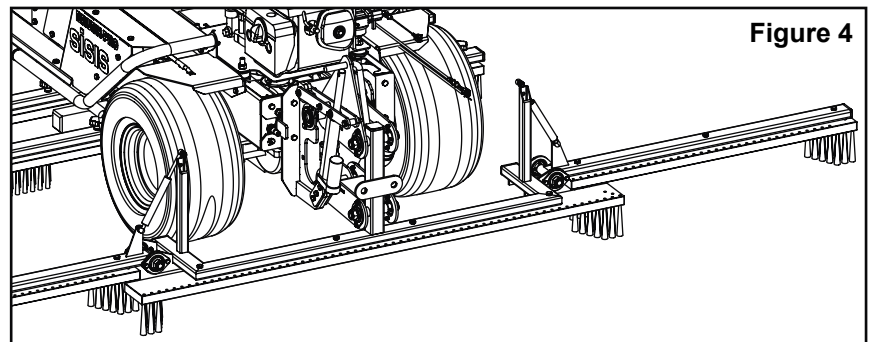

To engage the oscillating motion pull the centre brush drive lever back to the on position, (**See Figure 5**). Both the mechanisms that control the brushes compensate for ground clearance allowing them to be fully lowered onto the ground. The engine will cutout if the centre brush drive is engaged with the brake lever in the on position, thus protecting the centre brush oscillating mechanism.

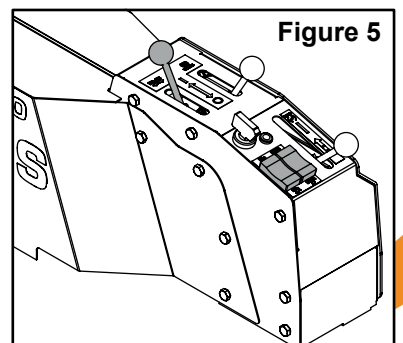

## TRANSPORT

Disengage the rear wheel drive by pushing in the drive engage lever fully in (*See Figure 6*). This allows the machine to be manoeuvred for transportation. When moving the machine by hand best practice is to hold the machine by the floor tubes, or if towing use the front bumper tube.

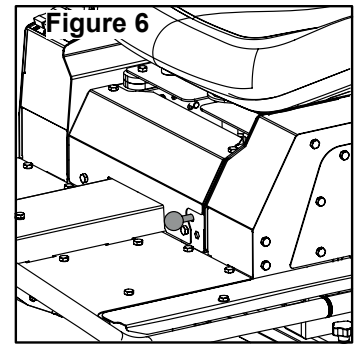

## MAINTENANCE

**Engine** - Honda GXV390 7.6kW 10.2 HP

**Engine Oil** - SAE 10w-40

**Hydrostatic Axle Oil** - SAE 10W-30

**Tyre Pressures** - Front 25 PSI, Rear 25 PSI

**Battery** - 12 VDC

**Drive** - Hydrostatic transaxle - rear axle

**Centre Brush Drive** - Belt drive



### **NOTE**

*CHECK TYRES ARE AT THE CORRECT PRESSURE, SEE ABOVE. CHECK ENGINE OIL LEVEL. CHECK BRUSHES FOR WEAR OR DAMAGE.*

- For access to the battery remove the left side top cover by loosening the screws as shown (*See Figure 7*).
- For access to the controls and tensioning cables remove the right side top cover (*See Figure 8*).
- For access to the centre brush mechanism remove all side covers (*See Figure 9*).
- For access to the machine drive mechanisms remove the front cover and seat plate (*See Figure 9*).

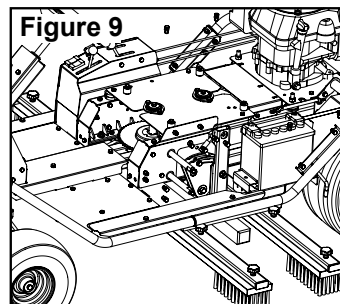
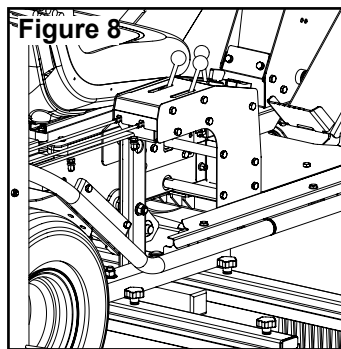
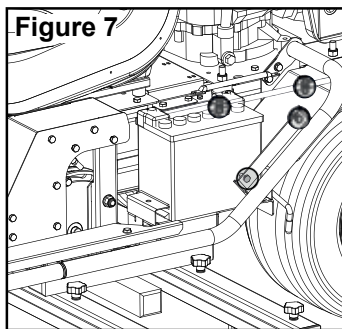

## BELT TENSIONING

The **Brush-Pro** uses two tensioning cables for the engagement of the belt drive and rear hydrostatic axle brake. Remove the right side cover to get access to the tensioning nuts for tension adjustment (*See Figure 8*).

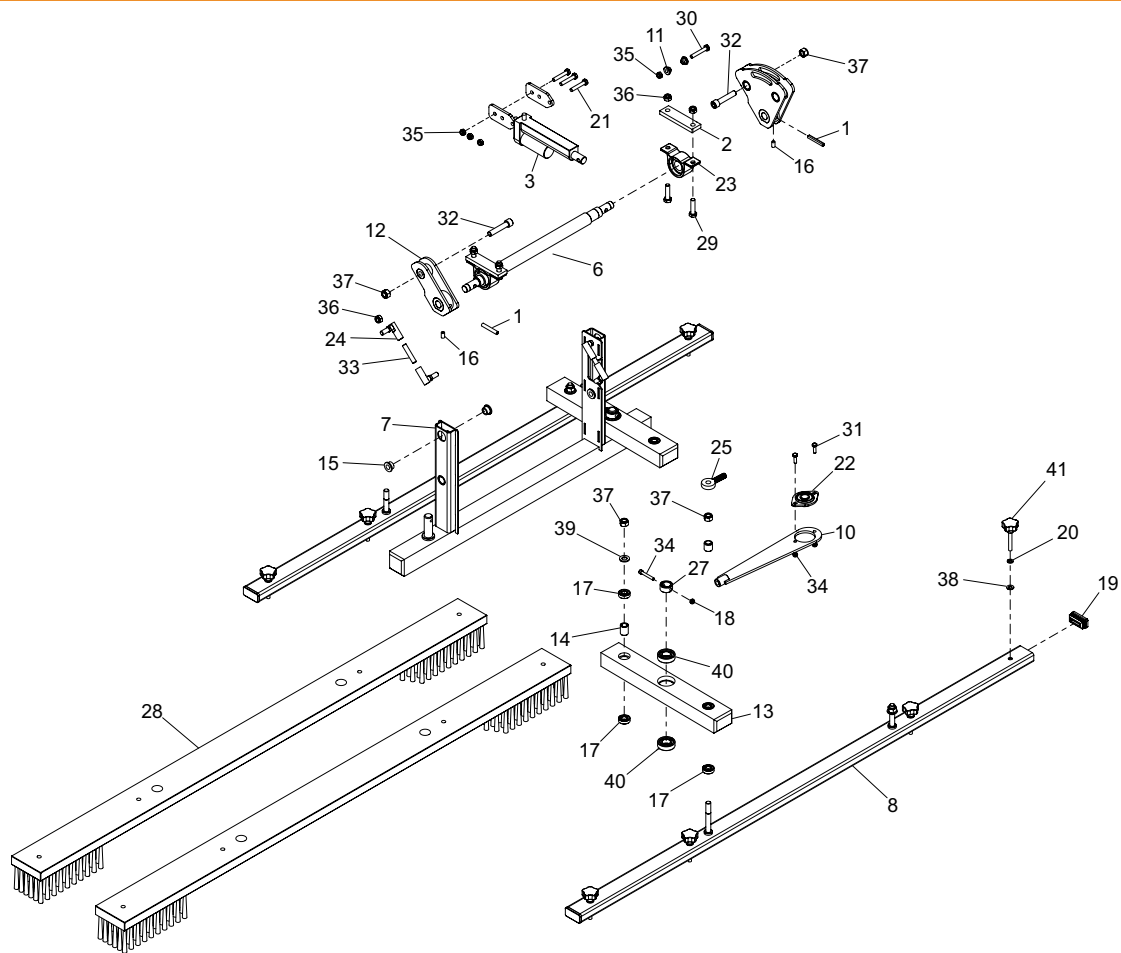

## 1.01

## Centre Brushes

Item No.	Part No.	Description	Quantity	Item No.	Part No.	Description	Quantity
1	228054	Spirol Pin (M8 x 50)	2	38	SP03008	Washer M8 Form A	8
2	401206	Bearing Spacer	2	39	SP03012	Washer M12 Form A	3
3	401229	Plate Actuator Link	2	40	SP06017	Bearing 6004-2RS	4
4	401242	Brush Holder Assembly	1	41	SP14013	Lobe Knob M8 x 55	8
5	401255	Angle Lift Plate WA	1				
6	401257	Centre Brush Shaft	1				
7	401301	Centre Brush Frame Assembly	1				
8	401302	Brush Holder Assembly	1				
9	401303	Spacer Rod End	1				
10	401304	Crank Arm	1				
11	401337	Boss Actuator	2				
12	401338	Angle Lift Plate WA	1				
13	401634	Pivot Arm Brush	2				
14	401659	Spacer Bearing	4				
15	BA1009	Bush Oilite AI1218	4				
16	D8154	Grub Screw M8 x 16	2				
17	D8173	Bearing 6001 2RS	8				
18	D8802	M6 x 40 Caphead	2				
19	D8956	Insert 50 x 25	4				
20	E1-1062	M8 Spring Washer	8				
21	E1-1110	Hex Set Screw M8 x 40	3				
22	SP06021	Bearing 2 Bolt Flange 16ID	1				
23	F21582	Bearing PB Asahi BPP 5.Z	2				
24	F21706	Ball Joint	4				
25	F22121	Rod End	1				
26	F22320	Linear Actuator 100mm	1				
27	F37340	Spacer	2				
28	F37575	Centre Brush (Black)	2				
28	SP24003	Centre Brush (Yellow)	2				
29	SP01020	Hex Set Screw M10 x 40	4				
30	SP01022	Hex Set Screw M8 x 50	1				
31	SP01028	Hex Set Screw M6 x 20	2				
32	SP01129	Cap Head M12 x 65	2				
33	SP01122	Rod M10 x 50	2				
34	SP02004	Nut M6 Nyloc	4				
35	SP02006	Nut M8 Nyloc (T)	4				
36	SP02008	Nut M10 Nyloc (T)	6				
37	SP02010	Nut M12 Nyloc (T)	6				



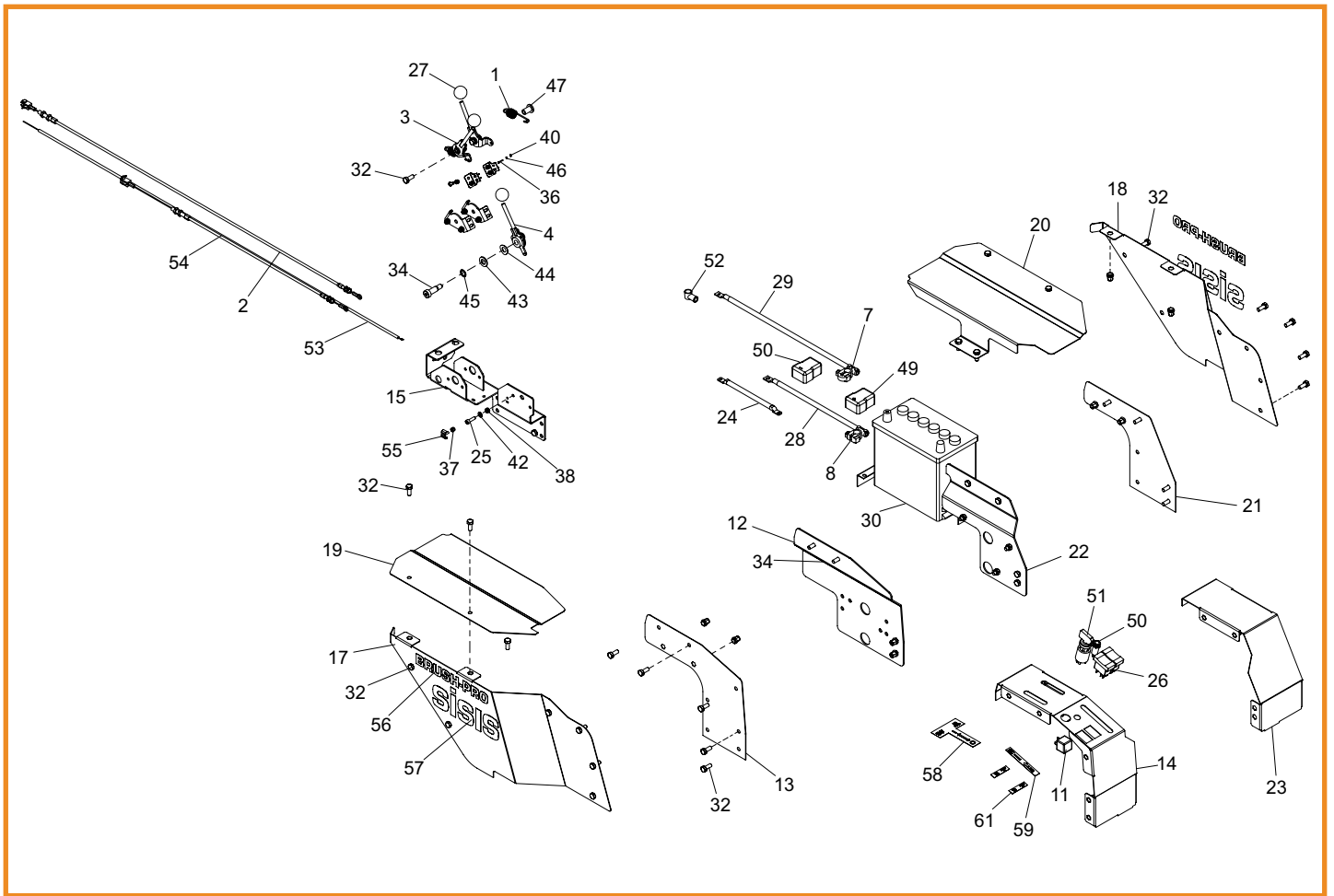

## 2.01

## Controls

Item No.	Part No.	Description	Quantity	Item No.	Part No.	Description	Quantity
1	229167	Clutch Spring	2	38	SP02004	Nut M6 Nyloc	5
2	229378	Cutter Drive Clutch Cable	1	39	SP02006	Nut M8 Nyloc (T)	5
3	230170	Lever R.H. W.A.	2	40	SP02032	Nut M2 Std	4
4	240140	Throttle Lever W.A. Sport	1	41	SP02044	Rivnut Hex M8 (0.5-3.0) [No Head]	25
5	240169	Sensor Angle Plate	2	42	SP03010	Washer M6 Form A	5
6	240171	Cutter Control Plate	2	43	SP03012	Washer M12 Form A	1
7	260135	Battery Positive Connector	1	44	SP03019	Washer M12 Wave	1
8	260136	Battery Negative Connector	1	45	SP03020	Shim 12 x 18 x 1	2
9	260145	Battery Eyelet 6mm	1	46	SP03027	Washer M2	4
10	260146	Battery Eyelet 6mm	1	47	SP06009	Bush Lever Pivot	2
11	260147	Relay	1	48	SP12030	Battery Positive Insulation Boot	1
12	401266	Control Panel Inner	1	49	SP12031	Battery Negative Insulation Boot	1
13	401267	Control Panel Outer	1	50	SP12044	Red Indicator Led 12V	1
14	401268	Control Panel Top	1	51	SP12045	Ignition Switch	1
15	401275	Throttle Brake Bracket WA	1	52	SP12046	Terminal Insulation Cover	1
16	401360	Battery Clamp Side	1	53	SP14014	Throttle Cable Brush Pro	1
17	401361	Side Panel Angled	1	54	SP14015	Belt Tensioner Cable Brush Pro	1
18	401362	Side Panel Angled LH	1	55	SP14016	Clamp Throttle Cable	1
19	401363	Side Panel Cover	1	56	SP18006	Decal Brush-Pro	2
20	401364	Side Panel Cover LH	1	57	SP18007	Decal SISIS Black	2
21	401423	Panel Outer LH	1	58	SP18008	Decal Brake Brush Brush Pro	1
22	401424	Panel Inner LH	1	59	SP18009	Decal Throttle Brush Pro	1
23	401425	Panel Top LH	1	60	SP18010	Decal Brush Up Brush Pro	1
24	D8712	Cable Earth	1	61	SP18011	Decal Brush Down Brush Pro	1
25	F20096	Cap Head M6 x 20	1				
26	F22327	Rocker Switch	2				
27	J20017	Knob - Red	3				
28	SP12057	Battery Negative Cable	1				
29	SP12058	Battery Positive Cable	1				
30	MD407	Battery (015)	1				
31	MD674	Battery Clamp	1				
32	SP01009	Hex Set Screw M8 x 20	43				
33	SP01019	Button Head M6 x 16	4				
34	SP01029	Shoulder Bolt 12 x 25 M10	1				
35	SP01069	Button Head M5 x 12	4				
36	SP01070	Cap Head M2 x 12	4				
37	SP02002	Nut M5 Nyloc (T)	5				

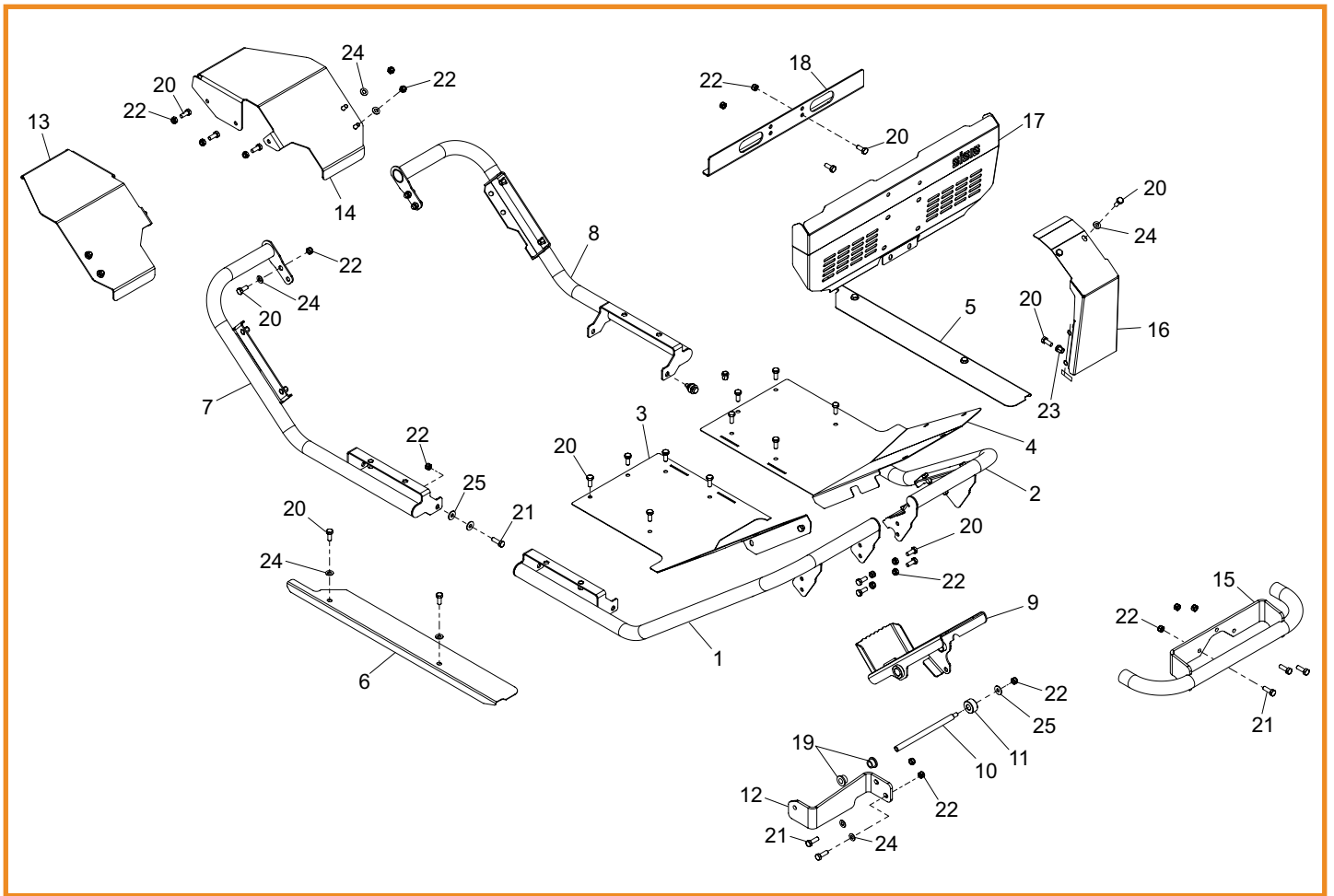

### 3.01

### Floor Assembly

Item No.	Part No.	Description	Quantity
1	401279	Front Tube WA	1
2	401285	Front Tube LH WA	1
3	401287	Front Corner Floor Plate	1
4	401288	Front Corner Floor Plate LH	1
5	401289	Floor Strip LH	1
6	401290	Floor Strip	1
7	401291	Rear Tube WA	1
8	401295	Rear Tube LH WA	1
9	401352	Pedal WA	1
10	401356	Pedal Axle	1
11	401357	Pedal Spacer	1
12	401358	Pedal Support Plate	1
13	401365	Rear Mudguard	1
14	401366	Rear Mudguard LH	1
15	401384	Front Tube WA	1
16	401387	Front Centre Cover	1
17	401388	Front Cover	1
18	401389	Front Cover Bracket	1
19	BA1009	Bush Oilite A11218	2
20	SP01009	Hex Set Screw M8 x 20	43
21	SP01045	Hex Set Screw M8 x 25	8
22	SP02006	Nut M8 Nyloc (T)	29
23	SP02044	Rivnut Hex M8 (0.5-3.0) [No Head]	18
24	SP03008	Washer M8 Form A	18
25	SP03015	Washer M8 Form C	5

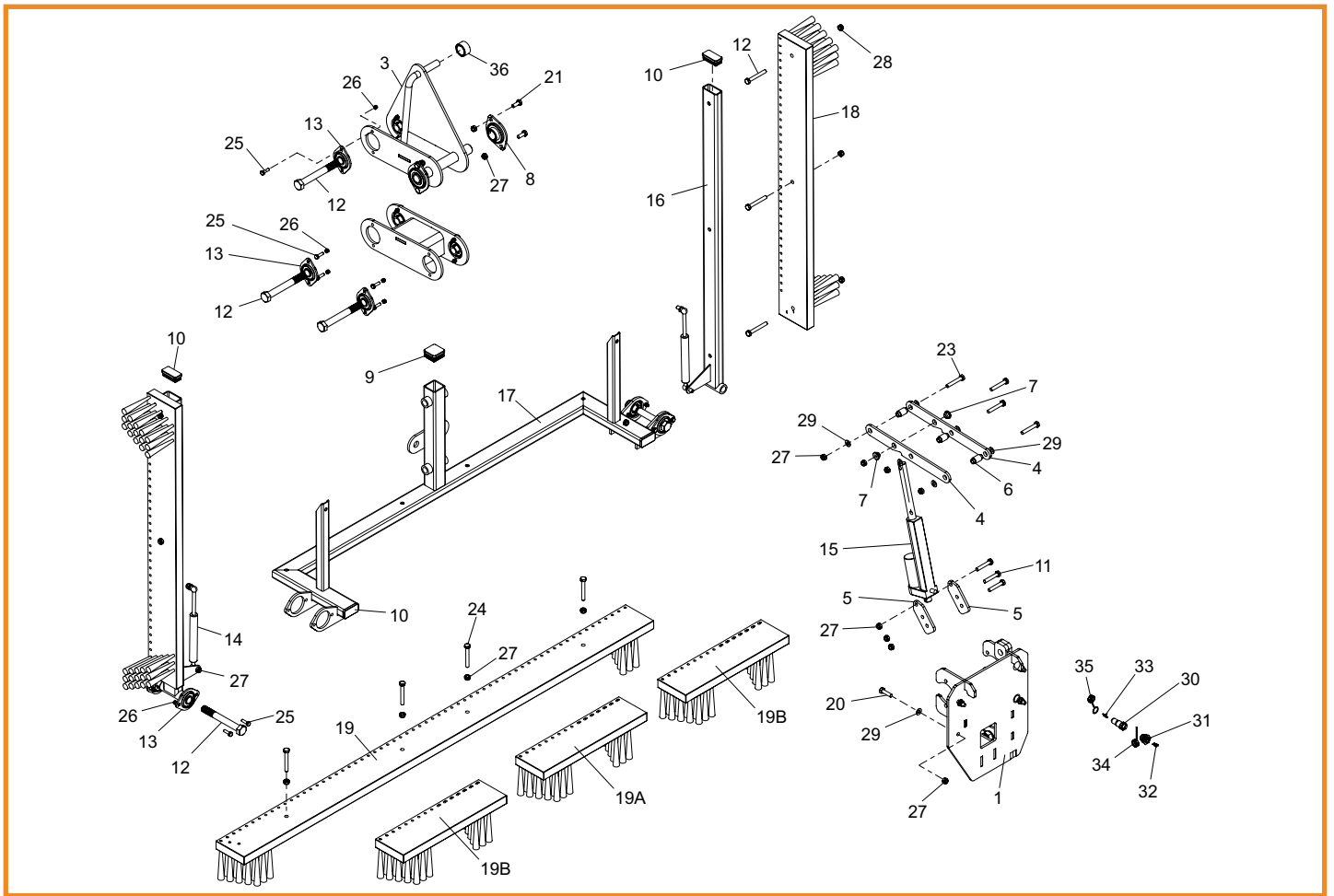

## 4.01

## Rear Brushes

Item No.	Part No.	Description	Quantity	Item No.	Part No.	Description	Quantity
1	401215	Rear Brush Support Frame	1	34	SP12036	Cap Sealing Chassis Connector	1
2	401216	Bottom Pivot Arm	1	35	SP12037	Cap Sealing Connector	1
3	401219	Top Pivot Arm WA	1	36	403137	Bush Lift Arm	1
4	401225	Lift Arm Link	2				
5	401229	Plate Actuator Link	2				
6	401336	Boss Angle Plate	3				
7	401337	Boss Actuator	2				
8	D8032	Bearing Flange 25ID	2				
9	D8955	Tube Bung 40 x 40	1				
10	D8956	Insert 50 x 25	4				
11	E1-1110	Hex Set Screw M8 x 40	3				
12	E1-1181	M16 x 130 Hex Bolt	5				
13	SP06021	Bearing 2 Bolt Flange 16ID	10				
14	F22314	Gas Strut	2				
15	F22319	Linear Actuator 130	1				
16	F37330	Rear Side Brush Frame WA (Black)	2				
16	403135	Rear Side Brush Frame WA (Yellow)	2				
17	F37332	Rear Brush Frame WA (Black)	1				
17	403130	Rear Brush Frame WA (Yellow)	1				
18	F37598	Rear Side Brush (Black)	2				
18	SP24006	Rear Side Brush (Yellow)	2				
19	F37599	Rear Brush (Black)	1				
19A	403134	Rear Brush (Yellow)	1				
19B	SP24006	Rear Brush (Yellow)	1				
20	SP01005	Hex Set Screw M8 x 30	4				
21	SP01009	Hex Set Screw M8 x 20	4				
22	SP01022	Hex Set Screw M8 x 50	1				
23	SP01022	Hex Set Screw M8 x 50	3				
24	SP01023	Hex Set Screw M8 x 60	10				
25	SP01028	Hex Set Screw M6 x 20	20				
26	SP02002	Nut M5 Nyloc (T)	20				
27	SP02006	Nut M8 Nyloc (T)	29				
28	SP02028	Nut M16 Nyloc (T)	5				
29	SP03008	Washer M8 Form A	10				
30	SP12032	Connector Bulgin Skt 2W	1				
31	SP12033	Chassis Connector Bulgin Pin 2W	1				
32	SP12034	Pin Contact 2W Bulgin Soldered	2				
33	SP12035	Socket Contact 2W Bulgin Soldered	2				

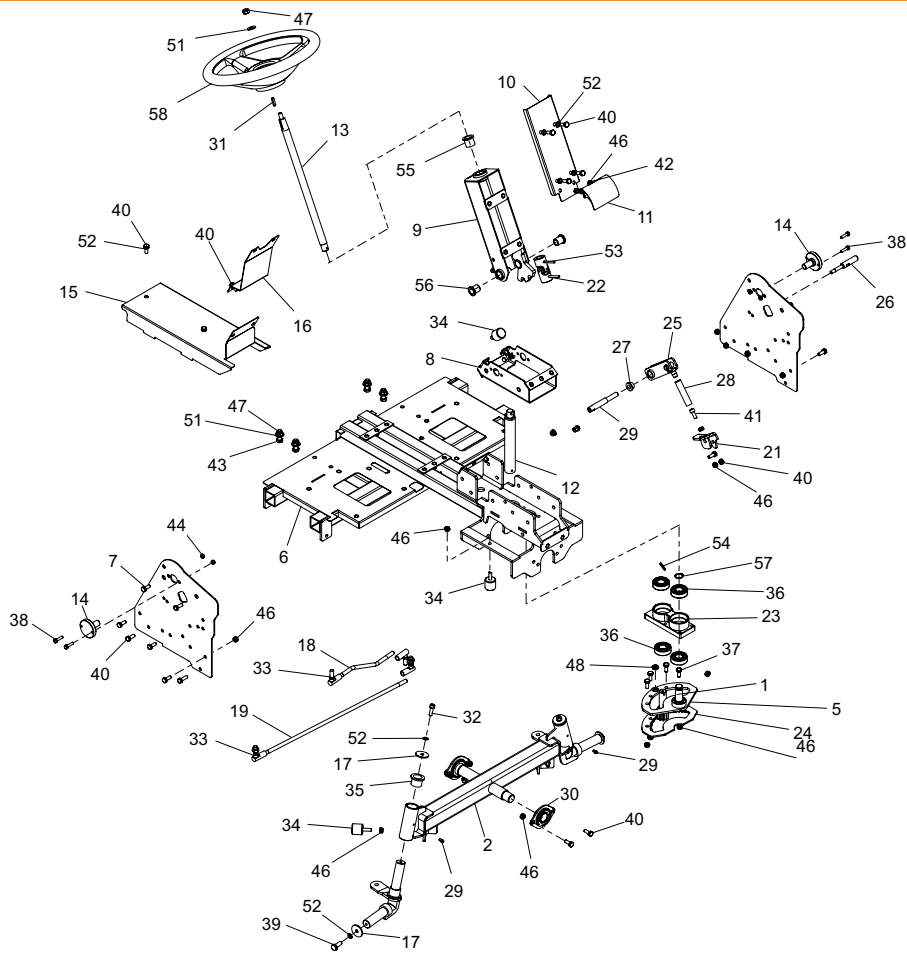

## 5.01

## Steering Assembly

Item No.	Part No.	Description	Quantity	Item No.	Part No.	Description	Quantity
1	229011	Pinion Shaft 11T	1	39	SP01035	Hex Set Screw M10 x 25	2
2	401230	Suspension Arm Assembly	1	40	SP01045	Hex Set Screw M8 x 25	28
3	401263	Stub WA 2	1	41	SP01049	Cap Head M8 x 20	2
4	401265	Stub WA 1	1	42	SP01076	Hex Set Screw M8 x 16	2
5	401274	Steer Rack WA	1	43	SP01105	Hex Set Screw M10 x 30	4
6	401323	Steering Frame WA	1	44	SP02004	Nut M6 Nyloc	4
7	401330	Steering Side Plate	2	45	SP02005	Nut M8 Std	2
8	401368	Steering Upper Bush WA	1	46	SP02006	Nut M8 Nyloc (T)	30
9	401371	Steering Column WA	1	47	SP02008	Nut M10 Nyloc (T)	7
10	401376	Steering Column Cover	1	48	SP02013	Nut M10 Lock (Thin)	1
11	401377	Column Pivot Cover WA	1	49	SP02044	Rivnut Hex M8 (0.5-3.0) [No Head]	29
12	401391	Steering Connecting Shaft	1	50	SP03008	Washer M8 Form A	4
13	401392	Steering Wheel Shaft	1	51	SP03016	Washer M10 Form C	5
14	401393	Column Pivot Spigot	2	52	SP03029	Washer M8 Spring Lock	13
15	401394	Centre Cover	1	53	SP05008	Pin Spirol M5 x 50	2
16	401395	Centre Pocket Cover	1	54	SP05013	Pin Spirol M5 x 30	1
17	F35835	Shaft Washer	4	55	SP06006	Bush Oilite AI2026 - 25	1
18	401430	Steering Connecting Rod	1	56	SP06018	Bush Oilite Flanged AI1620 - 25	2
19	401431	Steering Rod	1	57	SP07006	Circlip D1400 - 20	1
20	401525	Latch Pivot Pin	1	58	SP14012	Steering Wheel 12" Plastic	1
21	401606	Bracket Spring Lower	1				
22	401607	Steering UJ Machined	1				
23	401620	Steering Bearing Housing	1				
24	401623	Steering Plate	1				
25	401635	Latch Arm WA	1				
26	401639	Latch Foot Pin	1				
27	BA1009	Bush Oilite AL1218	2				
28	D1376	Spring 1/2" Bore x 14 Swg x 3	1				
29	D1947	Grease Nipple M6	2				
30	D8032	Bearing Flange 25ld	2				
31	D8035	Key Parallel 5 x 5 x 25	1				
32	F20384	Caphead M8 x 25	2				
33	F21706	Ball Joint	4				
34	F21739	Bobbin M8 Rubber	5				
35	F22396	Oilite Bush 25 x 30 x 25 Flanged	4				
36	J20052	Bearing 6204-2RS 3	4				
37	SP01009	Hex Set Screw M8 x 20	4				
38	SP01015	Hex Set Screw M6 x 25	4				

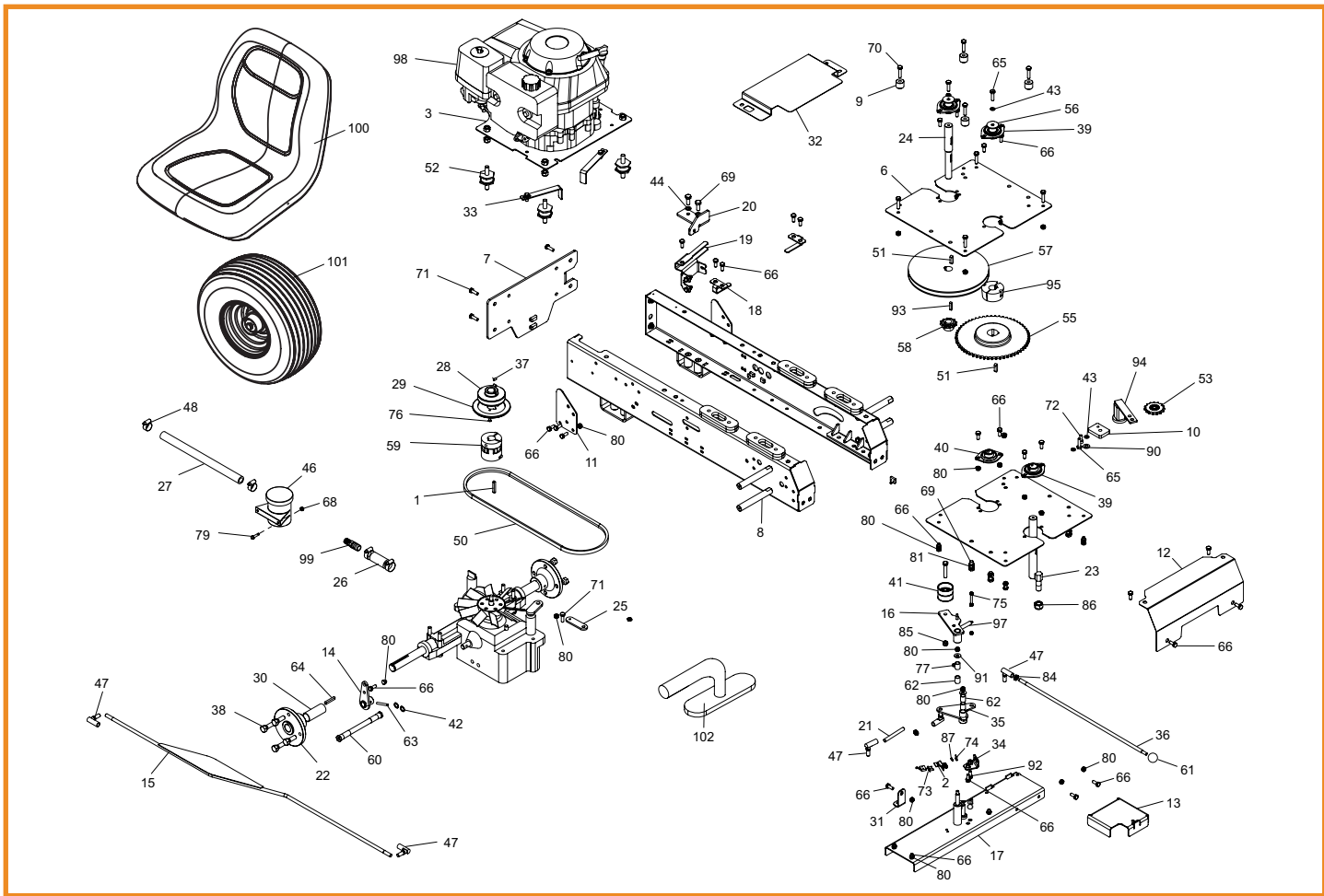

## 6.01

## Main Chassis

Item No.	Part No.	Description	Quantity	Item No.	Part No.	Description	Quantity
1	20194	Key 1/4" x 1/4" x 2" Rd End	1	53	F22078	15T Sprocket	1
2	240169	Sensor Angle Plate	1	54	F22269	Gearbox	1
3	401200	Engine Plate	1	55	F22326	57T Sprocket	1
4	401204	Frame Weldment LH	1	56	F35835	Washer	2
5	401205	Frame Weldment RH	1	57	F37300	250PCD Pulley	1
6	401209	Upper Lower Drive Plate	2	58	F37302	12T 0.5P Sprocket	1
7	401239	Backplate WA	1	59	F37358	Spider Coupling MC From 22329	1
8	401269	Control Panel Post	4	60	F37611	Hydraulic Hose Assy	1
9	401277	Seat Rail Boss	4	61	J20017	Knob - Red	1
10	401278	Tensioner Offset Plate	1	62	J209085	Bush Oilite Am1216 - 20	4
11	401297	Rear Tube Face Plate	2	63	J209104	Pin Spirol M6 x 50	1
12	401299	Chassis Front Cover	1	64	MD919	Key 1/4" x 1/4" x 1 3/4" Rd End	2
13	401300	Battery Support Bracket	1	65	SP01005	Hex Set Screw M8 x 30	3
14	401319	Speed Connecting Rod WA	1	66	SP01009	Hex Set Screw M8 x 20	45
15	401322	Pedal Connecting WA	1	67	SP01013	Hex Set Screw 3/8" UNF x 2"	1
16	401342	Belt Tensioner WA	1	68	SP01015	Hex Set Screw M6 x 25	2
17	401347	Tensioner Bracket WA	1	69	SP01035	Hex Set Screw M10 x 25	6
18	401348	Belt Finger Brush Pulley	2	70	SP01036	Hex Set Screw M8 x 35	8
19	401349	Belt Finger Cable Bracket	1	71	SP01045	Hex Set Screw M8 x 25	5
20	401350	Brake Cable Brcket	1	72	SP01049	Cap Head M8 x 20	1
21	401351	Axle Engage Rod	1	73	SP01069	Button Head M5 x 12	2
22	401367	Wheel Hub	2	74	SP01070	Cap Head M2 x 12	2
23	401428	Sprocket Drive Shaft WA	1	75	SP01108	Hex Set Screw M6 x 40	1
24	401429	Pulley Drive Shaft	1	76	SP01123	Csk Socket Screw M5 x 12	3
25	401432	Brake Link	1	77	SP02002	Nut M5 Nyloc (T)	4
26	401433	Axle Hose 3/4"	1	78	SP02003	Nut M6 Std	1
27	401434	Tank Hose 5/8"	1	79	SP02004	Nut M6 Nyloc	3
28	401590	Pulley 80Pcd A Rosca	1	80	SP02006	Nut M8 Nyloc (T)	45
29	401591	Pulley Belt Disc	1	81	SP02008	Nut M10 Nyloc (T)	4
30	401601	Tube Axle	2	82	SP02010	Nut M12 Nyloc (T)	8
31	401602	Axle Support Bracket	1	83	SP02012	M8 Thin Lock Nut	1
32	401608	Centre Cover	1	84	SP02013	Nut M10 Lock (Thin)	2
33	401611	Belt Guide	2	85	SP02018	Nut 3/8" Unf Nyloc (T)	1
34	401616	Bracket Ms Drive Engage	1	86	SP02028	Nut M16 Nyloc (T)	1
35	401788	Crank Drive Engage WA	1	87	SP02032	Nut M2 Std	2
36	401789	Rod Drive Engage	1	88	SP02044	Rivnut Hex M8 (0.5-3.0) [No Head]	14
37	D1989	Grub Screw M6 x 10	2	89	SP03008	Washer M8 Form A	4
38	D7094	Wheel Bolt M12	8	90	SP03011	Washer M10 Form A	2
39	D8032	Bearing Flange 25ID	3	91	SP03015	Washer M8 Form C	7
40	D8048	Bearing Flange Mounted 20 Bore	1	92	SP03029	Washer M8 Spring Lock	2
41	SP11035	Pulley	1	93	SP10005	Key 6 x 6 x 30 Rd End	1
42	403138	Pulley Spacer	1	94	SP11008	Tensioner Arm SE15	1
43	D8907	Washer Copper 1/4" Bsp	2	95	SP11026	Tapered Bush 2012 - 25mm	1
44	E1-1062	M8 Spring Washer	8	96	SP12008	Micro Switch Wheel	1
45	E1-1063	M10 Spring Washer	6	97	SP13005	Spring Tension 0.91 x 11.1 x 63.5	1
46	E1-1134	Hex Set Screw M10 x 80	4	98	SP15002	Engine Honda GXV390	1
47	F20664	Reservoir	1	99	SP26006	Hose Reducer 3/4" To 5/8"	1
48	F21623	Jubilee Clip 1A	2	100	F22358	Seat	1
49	F21706	Ball Joint	5	101	F20783	Wheel Assembly (Smooth)	2
50	F21774	Belt V 1EJ Cotton A50 1300	1	101	SP09004	Wheel Assembly (Treaded)	2
51	F21784	Key 8 x 7 x 30	2	102	F22269A	Connector	1
52	F21922	Vibration Mount	4				

# sisis®

SISIS, Ashbourne Road, Kirk Langley, Derbyshire, DE6 4NJ, England.

Tel: +44 (0) 1332 824 777 | Fax: +44 (0) 1332 824 525 | Email: [info@sisis.com](mailto:info@sisis.com) | [www.sisis.com](http://www.sisis.com)

A division of Howardson Ltd. - a proudly British company  
Company reg no 641526 - Vat No GB 345 9918 12